

DVB-H/T SINGLE-CHIP DIGITAL TV TUNER AND DEMODULATOR

FEATURES

- **Multiband**
 - VHF III (170 MHz – 240 MHz)
 - UHF IV, V (470 MHz – 862 MHz)
 - L-band (1400 MHz – 1700 MHz)
- **Standards compliance**
 - DVB-H (ETSI EN 302 304), DVB-T (ETSI EN 300 744)
 - IEC 62002 (MBRAI)
 - Supports DVB-H parallel and/or consecutive streams and services
 - Nordig Unified v1.0.3, Digitenne, and D-Book
- **Low power**
 - 209 mW in continuous operation with significant margin over MBRAI, Nordig Unified, Digitenne, and D-Book specifications
 - Between time-slice power: < 0.8 mW in DVB-H mode
- **High integration**
 - RF and digital sections on a monolithic 65-nm digital CMOS die
 - 4 Mb of on-chip MPE-FEC SRAM
 - PID, table ID, and IP filtering all on-chip
 - Integrated low-noise amplifiers
 - Fractional-N synthesizer supports 10 MHz – 66 MHz crystal
- **Excellent DVB-H Doppler performance**
 - $F_{D, \max} = 180$ Hz in 8K mode, 16 QAM $1/2$, GI $1/4$, MPE FER < 5%
- **High quality OptimRF™ tuner section**
 - High linearity: MBRAI specifications exceeded by a wide margin
 - Noise figure of 3 dB in all bands: VHF, UHF, and L
 - Ultra-low phase noise: < 0.5° RMS for UHF results with SNR > 35 dB
- **Wide range of interfaces**
 - SPI (slave and master, SDIO device)
 - 8-bit asynchronous parallel port
 - USB 2.0 device
 - I²C, UART, and JTAG for development
- **Package options**
 - 182-pin FBGA 8 mm × 8 mm, 0.5-mm pitch
 - 142-pin WLBGA 5.4 mm × 5.4 mm, 0.4-mm pitch

SUMMARY OF BENEFITS

- Ideal for broadcast TV in mobile phones, Portable Navigation Devices (PNDs), and Portable Media Players (PMPs).
- Single-chip mobile TV from antenna to IP stream.
- Standard 65-nm CMOS process for low bill-of-materials (BOM) cost.
- Allows DVB-H viewing at up to 220 Km/h in a channel at 600 MHz.
- High-performance, low power, and on-chip USB 2.0 enable both encrypted and free-to-air DVB-T reception on portable devices.
- Reception of up to 32 simultaneous DVB-H services allows viewing and recording of multiple video channels while displaying data services such as ESG, stock ticker, etc.
- Flexibility for addressing the global broadcast market with a single solution.
- **Low RBOM, minimum external components:**
 - No IF filters or RF tracking filters are required.
 - LNAs for all bands are on-chip.
 - No external SRAM or DRAM is needed.
- Excellent RF performance even with a single input for VHF and UHF that is single-ended (no balun).
- No calibration is needed during production.
- WLBGA package is ideal for dense cell phone PCBs and modules.

APPLICATIONS

- DVB-H or DVB-T enabled mobile handsets
- Portable Navigation Devices
- Portable Media Players
- DVB-T PC TV add-ons

Block Diagram

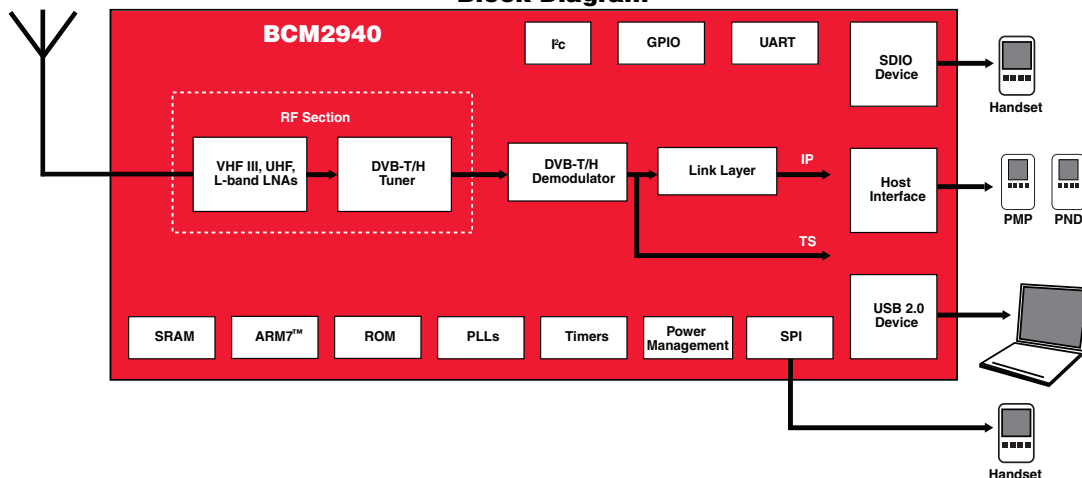

OVERVIEW

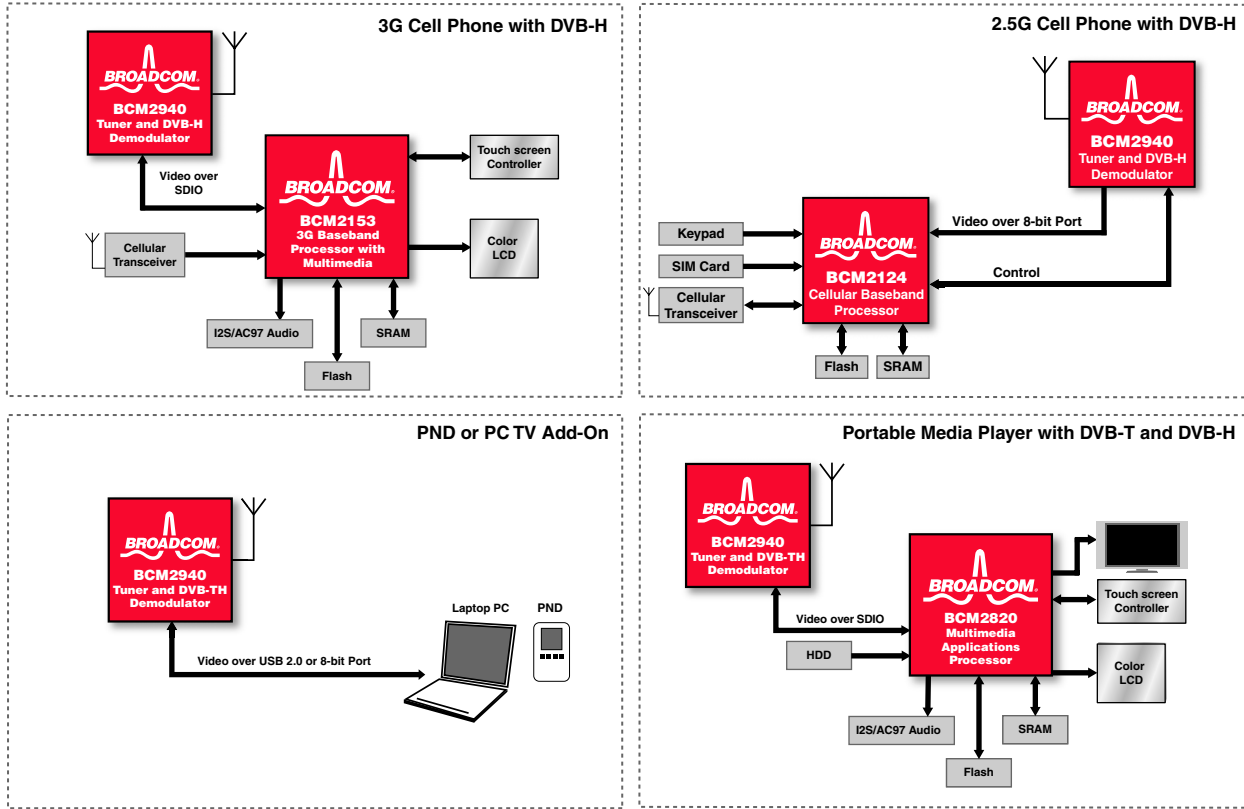

Handset, PND, and PMP Application Diagrams

The Broadcom BCM2940 is a monolithic 65-nm single-chip mobile digital TV receiver for both DVB-T and DVB-H standards. Combining a high-quality RF tuner with a complete DVB-T/H digital baseband on a single monolithic CMOS IC, the BCM2940 sets new standards for integration and mobile performance. The BCM2940 supports VHF III, UHF IV and UHF V bands, and both 1450 MHz - 1490 MHz and 1670 MHz - 1675 MHz L-bands. It is suitable for digital TV reception on portable devices almost anywhere in the world.

Broadcom's OptimRF technology is based on the optimal combination of state-of-the-art CMOS RF design and proprietary architectural and algorithmic innovations. OptimRF technology compensates for process and performance deviations, keeping device operation within target specifications. OptimRF improves manufacturing yield by avoiding costly trimming and optimizing power consumption.

Designed for integration with digital logic, the direct conversion tuner architecture doesn't require any external IF components, image-reject filters or tuner components. With on-chip demodulation, link layer

processing, error correction and associated 4 Mb MPE-FEC SRAM, the BCM2940 has everything required to receive an RF signal and to output digital TV. Video and audio are sent either as IP datagrams or as a complete MPEG-2 transport stream and can be handled over a variety of physical interfaces including SPI, SDIO, and USB 2.0.

Digital TV is becoming ubiquitous and is increasingly appearing on handheld devices. Handsets are becoming available with TV receivers designed for mobile broadcast standards such as DVB-H and DVB-T, which are targeted for small, battery powered applications. PNDs and PMPs with Mobile TV functionality support the ubiquitous DVB-T standard with free-to-air transmissions and enable viewing of downloaded and live content.

With its low power, small size, excellent performance and high-level of integration, the BCM2940 is the ideal choice for portable digital TV applications. When used together with Broadcom's multimedia processors and wireless communications chipsets, it forms a complete platform solution for TV-enabled handset, PND and PMP applications.

Broadcom®, the pulse logo, Connecting everything®, the Connecting everything logo, and OptimRF™ are among the trademarks of Broadcom Corporation and/or its affiliates in the United States, certain other countries and/or the EU. Any other trademarks or trade names mentioned are the property of their respective owners.

Connecting
everything®



BROADCOM CORPORATION

5300 California Avenue
Irvine, California 92617

© 2008 by BROADCOM CORPORATION. All rights reserved.

2940-PB06-R 12/02/08

Phone: 949-926-5000
Fax: 949-926-5203
E-mail: info@broadcom.com
Web: www.broadcom.com